

PROPRIETARY DATA: THIS DOCUMENT AND INFORMATION CONTAINED MAY NOT BE REPRODUCED, USED OR DISCLOSED WITHOUT THE WRITTEN PERMISSION OF THERMAL PRESS INTERNATIONAL, INC.

DWG NO. 40000		SH 1	REV A	1
REVISIONS				
INCORP	REV	DESCRIPTION	DATE	CHK'D/APVD
		PRELIMINARY - FOR REFERENCE ONLY		

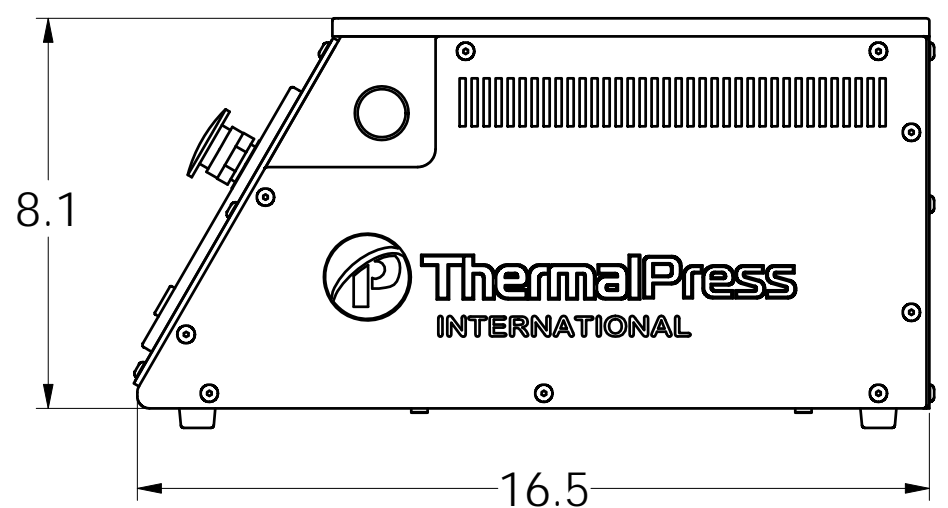
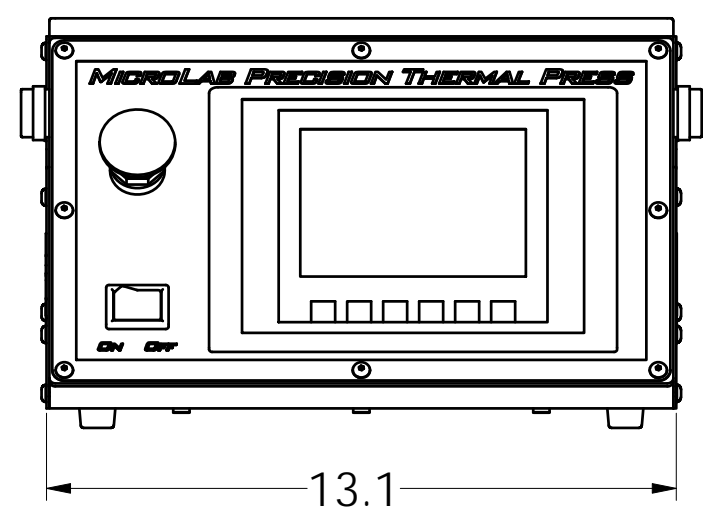
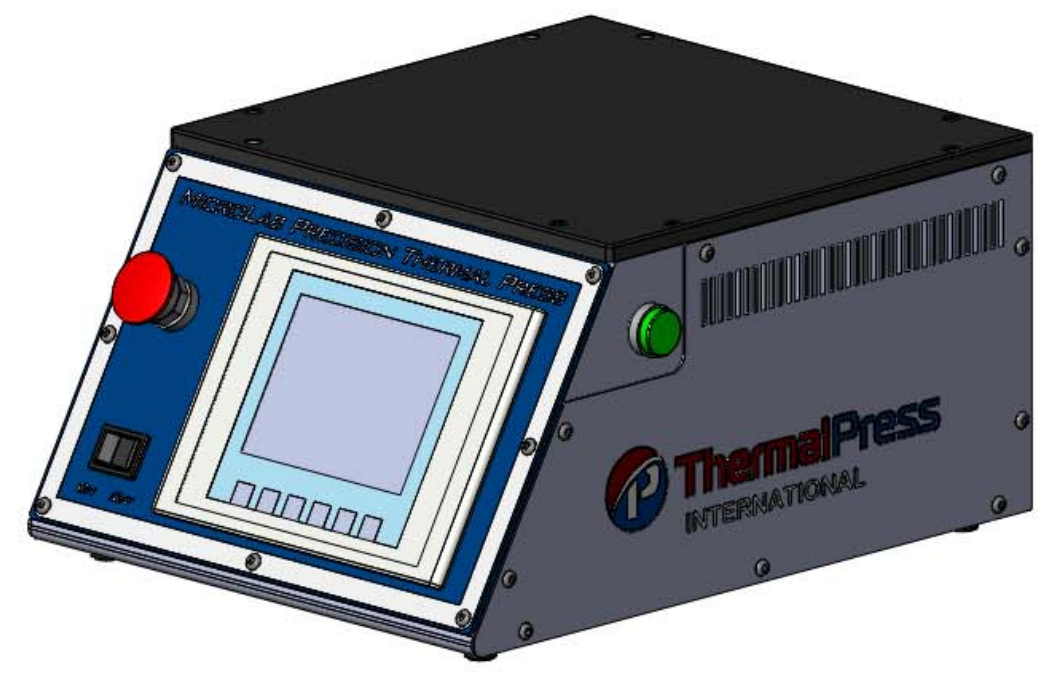
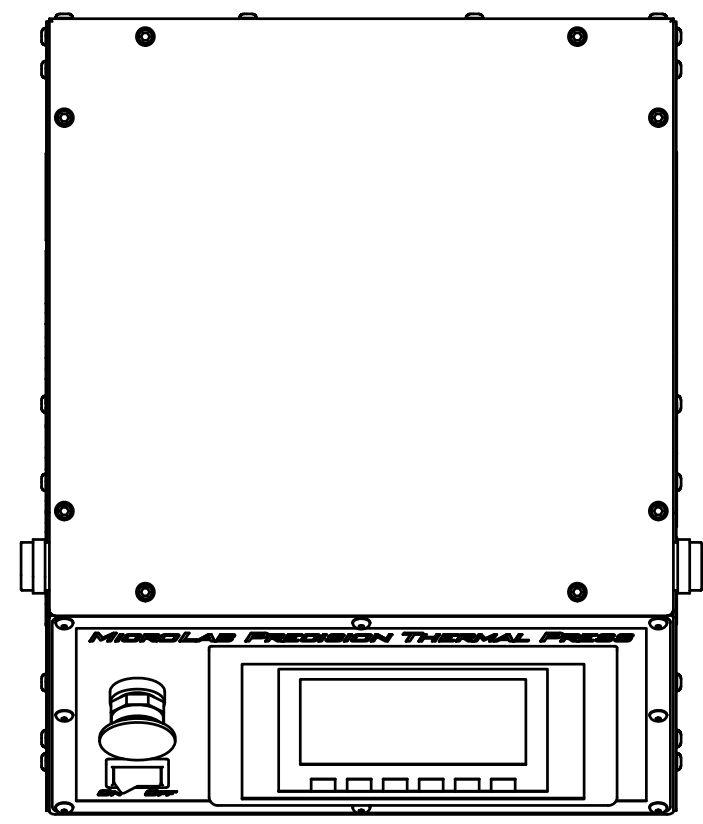

<b>DO NOT SCALE DRAWING</b> <small>UNLESS OTHERWISE SPECIFIED DIMENSIONS ARE IN INCHES DIMENSIONS IN [ ] ARE IN MILLIMETERS TOLERANCES APPLY AFTER FINISH</small> <small>DECIMALS .XX ±.01 [0.25] ANGLES ±1°</small> <small>.XXX ±.005 [0.127]</small> MATERIAL SEE NOTES FINISH 63 FAO	<b>APPROVALS</b> DRAWN D. PELLOW CHECKED I. McLEAN DESIGN ENGINEER I. McLEAN MFG ENGINEER	<b>DATE</b> 01/18/12 01/18/12 01/18/12	<b>Thermal Press International</b> www.ThermalPress.com USA (925) 454-9800 <b>TITLE</b> MICROLAB THERMAL PRESS ASSEMBLY
	Q.A. ENGINEER	SIZE D SCALE NONE DWG NO. 40000 REV	